



THE NATIONAL RECREATIONAL VEHICLE

# TOWING GUIDE

[ EDITION 8 ]



## KNOW YOUR WEIGHT



POWERED BY  
**PEDDERS**  
WEIGHT MATRIX™

Vehicle weight from accessories, towing and loads is a significant factor in the safety and performance of your vehicle, that's why Pedders have developed a world-first service - Pedders Tow and Load Assessment. Our Weight Matrix Software Report will assist you in understanding what your vehicle weighs now and in the future with your own tow and load scenarios.

Contact your local Pedders outlet for further information or book on line today.  
Visit [www.pedders.com.au](http://www.pedders.com.au)

## CONTENTS

DEFINITIONS.....	4
LEGAL REQUIREMENTS.....	10
TOW VEHICLE.....	12
TOWING PARTS.....	16
BRAKING SYSTEMS.....	25
TYRES.....	26
TOWING YOUR TRAILER.....	29
INSURANCE.....	36
A-FRAME TOWING.....	38
REAR MARKING PLATES.....	39
OFF HIGHWAY TOWING TIPS & TECHNIQUES.....	40
5TH WHEELER TOWING.....	43
PREPARATION.....	45
ORGANISATIONS FOR FURTHER INFORMATION.....	49

Edition 8. Published by: Caravan Industry Association of Australia, ABN 70 057 668 041,  
PO Box 788, PORT MELBOURNE VIC 3207, Phone (03) 9815 2015, January 2018.



## DEFINITIONS

In this Guide you will find a wealth of technical information, handy hints and advice, which, when put into practice, will help you to tow your Recreational Vehicle with a greater degree of confidence and safety.

Towing any type of trailer involves more than attaching a towbar to your vehicle and hitching up. It adds another dimension to your driving and there are a number of considerations you should take into account.

These include:

- the towing capacity of your vehicle;
- the type of tow bar you should fit to your vehicle and the maximum load capacity of the coupling;
- the maximum capacity of the trailer when fully loaded to the Aggregate Trailer Mass (ATM), specified by the trailer manufacturer, must not exceed the tow vehicle manufacturer's specified towing capacity;
- the ATM must be specified on the trailer's Vehicle (VIN) Plate;
- the type of trailer you are towing and whether it complies with all the regulations governing trailers in Australia;
- the type of equipment you may need to fit to increase the trailer's stability when being towed;
- whether your trailer is correctly loaded;
- the ways in which towing can affect your driving;
- the safety checks you should make prior to and during your trip; and
- the type of insurance most suitable for your caravan or trailer.

↗ **DOMETIC**

# MOBILE LIVING MADE EASY.

Dometic provide solutions that satisfy people's essential needs when living mobile. We offer smart and reliable products with outstanding design.

For more information visit [dometic.com](https://www.dometic.com) or freecall 1800 21 21 21.

## DEFINITIONS

### CARAVAN



Modern caravans are usually built using either a timber, aluminium frame, or sandwich panel, can vary in length from 3 to over 10 metres (maximum 12.5m including drawbar), can be up to 2.5 metres wide (including any fittings) with a maximum of 4.3 metres in height. They require very little time to set up on site but can have a higher wind resistance when towing than a pop-top caravan or a camper trailer.

### POP-TOP CARAVAN



Pop-tops feature a canvas, vinyl or fabric insert that connects the roof to the sides of the caravan. This insert allows the roof to be lowered for travelling. With the roof lowered, the vehicle's height, and therefore wind resistance, is reduced and its centre of gravity is lowered.

### CAMPER TRAILER



A Camper trailer is generally a lower profile Recreational Vehicle which consists of a wind up or push out roof section. A Camper Trailer may also have extendable bed sections at either end of the trailer. Camper Trailers are easy to tow and are often suitable for smaller tow vehicles.

### TENT TRAILER



Tent trailers are compact and popular for on-road or off-road use with their relatively light mass and low wind resistance. Tent trailers are easy to tow and are often suitable for smaller tow vehicles.

### 5TH WHEEL CARAVAN



5th Wheelers have all the features of a standard caravan but are designed to be towed by utilities or trucks. The towing connection is mounted on the tray of the tow vehicle, as close as possible to the rear axle. The 5th Wheeler's suspension carries the majority of its gross weight, with the balance distributed forward of the rear suspension over the differential rather than the extreme rear of the tow vehicle. Those towing 5th Wheelers should ensure that they do not exceed the axle capacity of the tow vehicle when the rig is connected.

### MOTORHOME



A motorhome is a self-powered unit driven from a cabin that allows easy access to the rest of the vehicle.

### CAMPERVAN



Campervans are a motorised van equipped with sleeping, refrigeration, sink, cooking and dining facilities designed for recreational travel.

### SLIDE-ON CAMPER



The slide-on camper is a caravan type body which slides on and is secured to the bed or tray of a utility.



**“...the caravan dropped into this pothole. Both of us were thrown around the vehicle cabin... I felt the caravan rock violently and then with relief I felt the ESC activate and the van was brought under immediate control.”**

*Alan Gostelow - Inverloch Victoria*

If you have to suddenly swerve to avoid a car when towing your caravan, AL-KO ESC is an emergency safety feature that will automatically activate to help keep your passengers safe. Why risk towing without it? **Tell us how ESC has helped you on the road - visit [www.alkoesc.com.au/ESCstory](http://www.alkoesc.com.au/ESCstory)**

**AL-KO**  
QUALITY FOR LIFE



FAITH/ALK0501

**GVM**   
(Gross Vehicle Mass)

The GVM is the maximum allowable total mass of a fully loaded motor vehicle, consisting of the tare mass (mass of the vehicle) plus the load (including passengers).

**GCM**   
(Gross Combination Mass)

GCM is the rating provided by the manufacturer of the tow vehicle. The maximum laden mass of a motor vehicle plus the maximum laden weight of an attached trailer is not permitted to exceed the GCM rating.

**ATM**   
(Aggregate Trailer Mass)

The total laden weight of a trailer, which includes the tow ball mass and whatever you add as payload (e.g.. water, gas, luggage). The ATM is specified by the trailer manufacturer and must not be exceeded

**GTM**   
(Gross Trailer Mass)

The total permissible mass which includes whatever you add as payload (e.g.. water, gas and luggage) that can be supported by the wheels of a trailer. This does not include the mass supported by the tow ball.

**Tare Mass**

The unladen weight of the complete new trailer as delivered (including any options fitted).

**Tow Ball Mass**

The weight imposed on the tow vehicle's tow ball by the coupling.

**Payload** 

The allowable load carrying capacity or 'payload' is worked out by deducting the "Tare Mass" from the "ATM". It must not be exceeded under any circumstances. Safety, insurance & warranty may be affected if the specified payload is exceeded.

This information may be located in your Tow Vehicle Owner's Manual and on your Trailer's Information Plate or "Vehicle Plate".

## LEGAL REQUIREMENTS

Towing requirements are legislated and policed at a state level. Details of these requirements can be sourced from the relevant State or Territory Transport Authorities.

Contact details for each of these state authorities can be found here:  
[www.australia.gov.au/about-government/states-territories-and-local-government](http://www.australia.gov.au/about-government/states-territories-and-local-government)

### SPEED LIMITS

Most states require towing vehicles to observe the same speed limits as any other road vehicle. However, some jurisdictions may vary from this. For example, Western Australia currently restricts any vehicle towing a caravan/trailer to a maximum speed limit of 100km/h or the posted speed limit, whichever is the lesser value.

It is recommended that you become familiar with the requirements for each state that you plan to visit.

Some tow vehicle manufacturers and Recreational Vehicle manufacturers may also stipulate a reduced speed limit for their vehicle (or trailer) when towing.

The respective Owner's Handbook will contain the details of any such restrictions.



At Camec, we live to create everyday comfort for our customers, no matter where their adventures take them. With outlets and retailers across Australia, we have all the parts and accessories you need for towing your caravan.

 **CAMEC**<sup>®</sup>  
 camec.com

## TOW VEHICLE

If you are going to purchase a trailer or caravan, it is critical that you give careful consideration to our vehicle's towing mass and construction prior to making your purchase.

You will find the towing mass (or towing rating) under the towing section in the vehicle manufacturer's handbook.

The rating will include a trailer weight capacity and a trailer ball weight capacity, both of which must not be exceeded.



HOME OF THE **DO35**



*Suitable for use with Hayman Reece, Milford & Ez-Lift WDH Systems - Not restricted by 50mm ball coupling height regulations*

LEARN MORE ABOUT OUR OFF-ROAD COUPLINGS AND PREMIUM SUSPENSION SYSTEMS AT [VEHICLECOMPONENTS.COM.AU](http://VEHICLECOMPONENTS.COM.AU)



## TOW VEHICLE

If no brakes are fitted to a trailer; then 750kgs is the maximum permissible towing capacity.

With regards to tow vehicles, the towbar fitted must not exceed the capacity approved by the vehicle manufacturer. In some cases some additional (strengthening) materials are supplied with the certified towbar as part of the fitting kit.

It may also be advisable to fit additional towing aids to enhance towing compatibility and safety.

These could include:

- Weight distribution hitches (sometimes colloquially called level rides). Seek expert advice on this type of equipment. Such devices should not be used with over-ride brakes.
- Fitting load levelling devices (frequently called weight distributing hitches or level rides). These must not be used with override brakes.

- The fitment of a 12V Electrical Connection on the tow vehicle (commonly a 7 or 12 pin socket) provides the electrical power needed to operate the trailer lights as well as the electric brakes that are fitted to most caravans. Note the operation of lamps is a mandatory requirement whilst towing.
- Fitting a suitable brake controller and connection: all trailers of 750kgs GTM or more must be fitted with brakes. Electric brakes are the most commonly used and require a brake controller, with appropriate connections to the trailer, to be fitted in the tow vehicle.
- Extra mirrors may need to be added to the tow vehicle when towing large trailers. It is a legal requirement that the driver has a clear and unobstructed view of the road to the rear of the vehicle or vehicle combination at all times.

Remember that towing a trailer or caravan will decrease your vehicle's acceleration and braking performance. It will also reduce vehicle control and manoeuvrability, while increasing fuel consumption.

Your vehicle's towing capacity is a factor of its engine size, brakes, weight, transmission, tyres, bearings, chassis, suspension etc.

After taking these variables into account, the vehicle's manufacturer establishes a recommended towing capacity, which is the legal maximum and must not be exceeded.

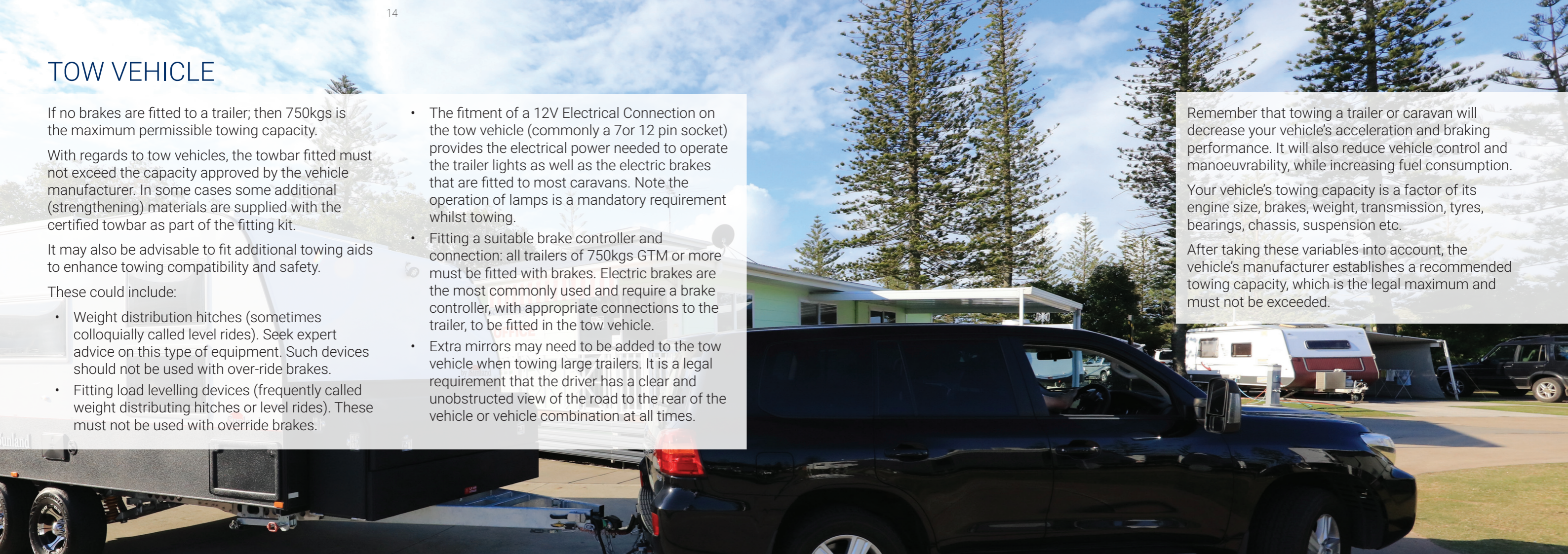



## TOWING PARTS

There are six main aspects involved in towing a trailer:

- The Towbar
- The Ball Mount or Tongue
- The Tow Ball
- The Coupling
- The Trailer Draw Bar or 'A' Frame
- The Safety Chains

### THE TOWBAR

The towbar is the framework attached to the back of the tow vehicle. For safe towing, a properly designed and fitted towbar with an adequate certified weight rating is mandatory.

Further, the load capacity of the towbar and the trailer coupling must be equal to or exceed the loaded mass of the trailer.

Unless a permanent part of the vehicle, it is compulsory for all towbars manufactured after 1 July 1988 to clearly and permanently display the maximum load rated capacity plus the make and model of vehicle for which they are intended, or alternatively, the manufacturer's name, trade mark and part number.

Check for this information to help you ascertain whether the towbar suits your needs.

**Note:** *Towbars should not protrude dangerously when your trailer is not connected.*

### FOR ALL YOUR CARAVANNING NEEDS

- Acrylics & Laminates
- Air Conditioning
- Antennas & TV Brackets
- Apple Products
- Bathroom Accessories
- Bed Base & Mattress
- Caravan Steps
- Composite Panels
- Decorative Plywood
- Flipdown Monitor
- Microwave Ovens
- Mini Washer
- One Piece Floor
- Powerpoints
- Rangehood
- Sinks & Basins
- Smart TV & HD TV
- Splashbacks
- Stereos & Speakers
- Tapware & Flick Mixers
- Timber Products
- Washing Machines
- WiFi Camera & Modem
- Windows & Blinds

Shop Online Now

[HOMEandRV.com.au](http://HOMEandRV.com.au)



nce

GREE

DAEWOO  
ELECTRONICS

CHANGHONG

AQUAPORT  
water for life

Apple  
Authorised Reseller

NCE PTY LTD

34-48 Stanley Drive  
Somerton VIC 3062

For wholesale enquiries contact the NCE Team

[sales@nce.com.au](mailto:sales@nce.com.au)

1300 366 024

[nce.com.au](http://nce.com.au)



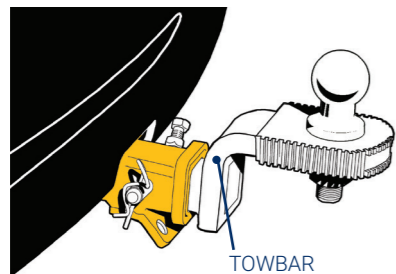

## THE TOW BALL

Based on Australian Design Rules & Standards, tow balls suitable for ATM weights up to 3500kg:

- Must be 50mm in diameter, and stamped on top of ball as a legal requirement.
- Must be a one piece element, the shank of which should be 29mm in diameter.
- Must be fitted to the vehicle with a locking washer and appropriately sized nut.
- Must have the manufacturer's name or trademark stamped on the flange of the towball.

With the tow vehicle loaded to GVM, the towbar (if fitted with a 50mm towball) on the towing vehicle must be capable of being mounted (adjusted) to any one height within the range of 350mm to 460mm (from the ground to the centre of the towball).

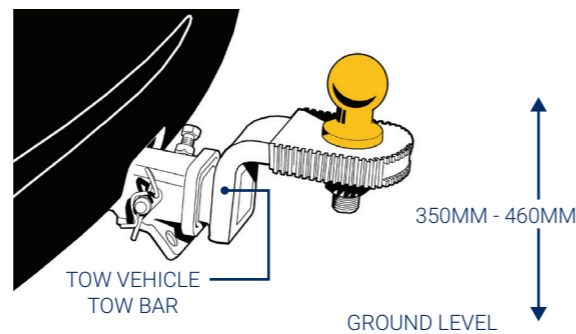

## THE BALL MOUNT OR TONGUE

The ball mount, also known as the tongue, is the section of the towbar to which the towball is attached. It is usually a flat 75mm wide, 16 to 20mm thick steel bar, which may be either straight or curved to achieve the correct coupling height.

If the ball mount or tongue obscures the number plate it must be removed from the towbar when the trailer is not attached.

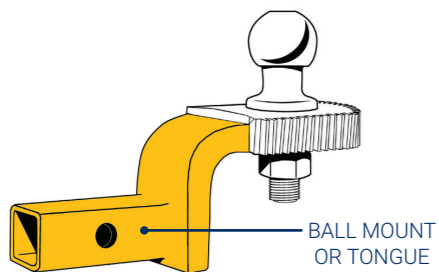

## TOWING PARTS

### THE COUPLING BODY

The coupling body is the section that is attached to the 'A' frame of the trailer. It forms a socket for the tow ball and provides the necessary pivot point between the trailer and the towing vehicle. Coupling bodies commonly in use can range in capacity from 750kgs to 3,500kgs. They must be marked with their capacity, as well as the manufacturer's name and the size of the tow ball for which they are suitable.

It is important to ensure that the coupling body's capacity exceeds or is at least equal to the fully laden weight of the trailer. Regardless of coupling capacity, the 50mm ball must still comply with the capacities outlined under the heading tow ball.

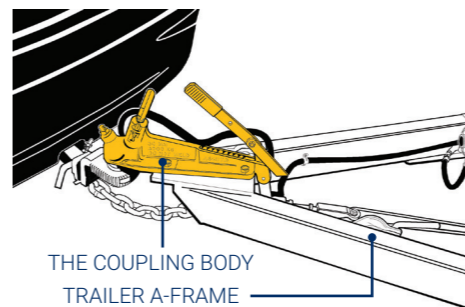

### OFF-ROAD COUPLINGS (NON 50MM BALL TYPE)

Off-Road couplings are designed for use where high degrees of articulation are required. Some use a separate pin to connect, whilst others use a built-in locking mechanism. Many have polyurethane components to absorb shocks.

All of these couplings are required to incorporate a positive locking mechanism plus a separate means of retaining this mechanism in the locked position. This locking must be readily verifiable by visual examination.

Both parts of the coupling must be marked with the Manufacturer's name or trademark, the words "use with model (identified model)" and the maximum allowable trailer ATM i.e. 3500kg at which the coupling is rated.

The coupling must be strong enough to take the weight of a fully loaded trailer.

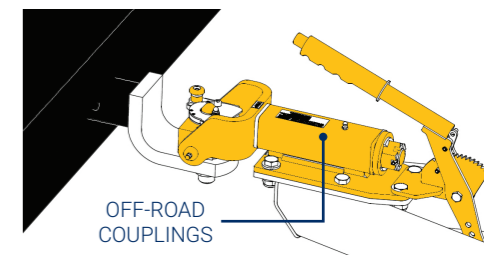



WITH OVER 60 PARKS IN SOME OF AUSTRALIA'S MOST BEAUTIFUL PLACES WE HAVE YOUR NEXT STOP COVERED.



Discover more and visit [www.discoveryholidayparks.com.au](http://www.discoveryholidayparks.com.au)



# Look for the Key



Your complete set of keys for industry improvement.

## TOWING PARTS

### THE TRAILER'S 'A' FRAME (DRAWBAR) & SAFETY CHAINS

This is the front section of the trailer or caravan chassis to which the coupling body is attached.

The "A" frame or drawbar is required under the Australian Design Rules to be of sufficient strength for the specified trailer ATM, and must be able to be proven to do so by engineering calculation.

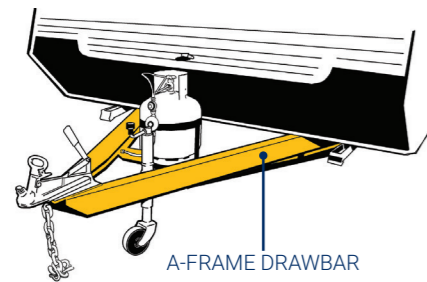

**Note:** It is not advisable to add additional items to the drawbar. Increasing the downward load on the trailer drawbar will also increase the tow-ball weight on the towbar. Excessive overloading of the towbar ball weight will affect its performance and may void manufacturer's warranty.



Safety chains are compulsory in all States and Territories of Australia. They must be strong enough to hold the trailer and prevent the drawbar from touching the ground, should the coupling fail or be accidentally disconnected from the ball.

Trailers less than 2,500kgs ATM must be fitted with at least one safety chain. Trailers over 2,500kgs ATM and up to 3,500kgs must have two safety chains fitted. Chains must comply with AS4177-4 and have a rating at least equal to the trailer ATM.

The chains attach the 'A' frame or drawbar of the trailer to the main towbar framework on the vehicle. The attachment must be fit for purpose of equivalent strength to the chains.

Safety chains must be stamped with the chain's capacity, the manufacturer's identification and the digits 4177.

The chains should be as short as possible, leaving only enough slack to permit tight turns. If two are required they should be crisscrossed under the trailer tongue to prevent the forward end of the drawbar from hitting the ground if the coupling becomes disconnected.

Safety Cables: Safety Cables of equivalent capacity to safety chains are also allowed on tow vehicles up to 3,500kgs ATM. It is vital that the chains are attached to the main towbar framework and not to a detachable ball mount or tongue.



# AVIDA Motorhomes & Caravans

*Discover your dreams*



## AUSTRALIA'S NO.1 MOTORHOME MANUFACTURER

**PEACE OF MIND**

- 3 YEAR** Factory Warranty or 1 Million Km
- 5 YEAR** Structural Warranty
- 2 YEAR** Roadside Assistance



Discover the Avida Range  
[www.avidarv.com.au](http://www.avidarv.com.au)



**WIN**  
a luxury 10 day adventure holiday in an Avida RV go to [winrv.com.au](http://winrv.com.au) and enter code **CIAA**

**MOTORHOMES**  
2-6 berth, low profile and multi terrain motorhomes

**CARAVANS**  
Light weight, luxury and family caravans



**CAMPERVANS**  
Compact & electric roll down bed campervans

**ELECTRIC POP TOPS**  
Queen, bunk bed & electric pop tops

## BRAKING SYSTEMS

According to the Australian Design Rules, all trailers over 750kgs GTM (irrespective of the towing capacity or unladen mass of the tow vehicle) must have an effective brake system fitted.

All brakes must be operable from the driver's seat of the tow vehicle except for over-ride brakes. The minimum braking system required for a trailer or caravan depends on its type and weight, as well as the weight of the tow vehicle:

- Up to 750kgs GTM: No brakes are required.
- 751-2,000kgs GTM: There must be a braking system on the wheels of at least one axle and over-ride brakes are permitted.
- Over 2,000kgs GTM: A brake system operating on all wheels is required. The system must be capable of automatically activating should the trailer become detached from the 12 VOLCABLE T ELECTRICAL tow vehicle. Under these circumstances the brakes must remain applied for at least 15 minutes. These 'break-away'

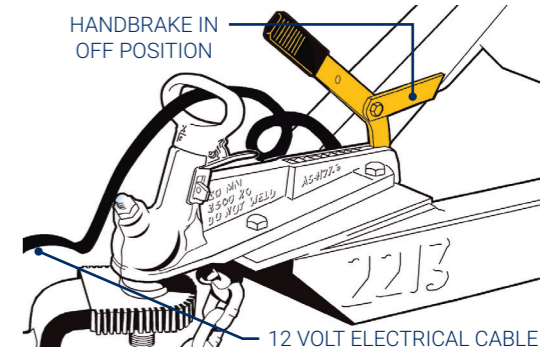

systems are compulsory on all trailers over 2,000kgs GTM.

- In some states there may be additional requirements that require an indicator light or audible signal showing the battery on board the caravan is sufficiently charged to enable the battery to satisfactorily activate the brakes, via the break-away system, on all wheels should the trailer detach from the tow vehicle. This indicator light must visible or heard from the driver's seated position and must operate only while the ignition is in the "engine on" position or whilst the engine is running. Contact your State or Territory roads and traffic authority regarding the requirement of a visible or audible indicator with your 'break-away' system.

## TYRES

It is vital that your tyres are in good condition. Tyres can deteriorate just as much when a vehicle stands for long periods, as when it is being used. As tyres age, the surface rubber can crack and rubber compounds can deteriorate.

Most Tyre Manufacturers recommend that tyres after 5 or more years of use be thoroughly inspected at least once per year by a professional.

If tyres are worn to the legal minimum tread depth, they must be replaced regardless of age. Remember to keep a spare that is the same, and gets replaced at the same time as the other tyres.

Tyres must have a sufficient load-rating and speed-rating for towing, and must have the correct tyre pressure to suit the load being carried. Tyre pressure maintenance is important, as properly inflated tyres will give you the best economy, safety and performance from your towing vehicle and caravan. Under inflated tyres can lead to the tyre walls becoming overheated and blowing out. Over inflation can cause severe vibration and stress to your caravan.

One way to decide on the correct tyre pressure is to check the tyre placards on the vehicle and the caravan. For the towing vehicle, the placard specifies the recommended pressures for both normal and maximum load conditions when the vehicle is operated for sustained periods at high speed. For safety and optimum tyre life, inflation pressures should be adjusted in accordance with the placard recommendations.

In addition to the towing vehicle's tyre placard, a plate affixed to the trailer will provide information on the trailers important ratings and tyre pressures.



## TYRE PRESSURE

The tyre pressure must be adjusted according to the load, and the best way to determine the optimum tyre pressure is to know the fully laden weight of the van. A trip to a weighbridge will establish this. Tables providing the correlation between load and pressure are available from your local tyre dealer. In addition, tyre pressures may need to be adjusted to suit differing road surfaces.

If in doubt, contact a tyre retailer. Correct tyre pressure will provide safe operation, maximum tyre life, the best ride, handling, and fuel economy.

## WHEELS, NUTS & STUDS

All wheel nuts must be carefully tightened to the correct torque, and in the correct pattern, in accordance with the instructions provided by the vehicle manufacturer.

The procedure for periodically checking the torque must also be in accordance with the instructions provided by the vehicle manufacturer.

**Warning:** Manufacturers of Recreational Vehicles are responsible for ensuring wheels, studs and nuts are fully compatible. If after-market wheels (and nuts) are fitted, the vehicle must be thoroughly inspected and written assurance that the replacement wheels, nuts & studs are in fact suitable for the vehicle and axle(s) must be provided.

# family adventures start here



**contact us today**  
to start your new adventure



[www.NewAgeCaravans.com.au](http://www.NewAgeCaravans.com.au)



## TOWING YOUR TRAILER

### THE DRIVER

Apart from adding to the driver's legal responsibilities, towing requires a greater degree of knowledge and skill than normal driving. When towing, you should:

- Allow for the extra length and width of the trailer when entering traffic;
- Apply the accelerator, brakes and steering smoothly and gently to avoid sway, especially in wet or slippery conditions;
- Maintain adequate space between you and the vehicle in front to allow for a longer stopping distance;
- Engage a lower gear in both manual and automatic vehicles to increase vehicle control and reduce brake strain when travelling downhill;
- Allow more time and a greater distance in which to overtake. When towing, your vehicle's capacity to accelerate is reduced;
- If possible, reverse with a person watching the rear of the trailer;

- Where areas are provided, pull off the road to allow traffic building up behind you to overtake;
- Be aware that towing is more stressful than normal driving and is more likely to cause fatigue. Therefore, more rest stops should be planned.

### ELECTRONIC STABILITY CONTROL (ESC)

Electronic Stability Control monitors the stability of the caravan and automatically apply the van's brakes when dangerous lateral movement is detected.

It is also important to pull over and investigate the source of the problem, which may involve an uneven load in the caravan itself.

Many aftermarket products exist to minimise sway, including ESC and stabiliser couplings with friction pads that grip the tow ball and dampen swaying movements.

### TOWING YOUR CARAVAN

The loaded mass of your trailer must not exceed:

- The capacity of the towbar; or

- The ATM rating as specified by the trailer manufacturer; or
- The maximum towing mass specified by the tow vehicle's manufacturer; or
- The maximum ball weight specified by the tow vehicle's manufacturer.

### CARAVAN SWAY

If your caravan begins to sway or snake, remain calm and avoid the urge to apply the towing vehicle's brakes. Don't try to steer out of the swaying / snaking. Alternatively hold the vehicle steady and try to stay in the lane.

Gently apply the caravan's electric brakes using the manual control in the tow vehicle. Otherwise, where conditions permit, continue at a steady speed or accelerate slightly until the sway stops.

When a condition of sway has been corrected, slow down and pull off the road safely. Check that your load is correctly distributed within the trailer, making sure that heavier items are placed over the axles of the caravan.

A caravan that doesn't have the load distributed correctly may not handle well and may be the cause of swaying / snaking.



### LOADING TRAILERS

It is important not to overload your trailer. You should not exceed the maximum load specified or recommended by the trailer manufacturer, nor should you exceed the tyre or coupling capacity. All trailers shall have a plate affixed displaying the ATM (Aggregate Trailer Mass) which is the maximum allowable weight of the loaded trailer.

For safety and ease of towing the ball mass (the mass towards the front of the trailer carried by the tow ball of the towing vehicle), should be about 10% of the total laden trailer weight. The ball mass can be measured either at a weighbridge by resting only the jockey wheel on the scale, or by placing a ball mass scale under the coupling then taking the weight off the jockey wheel. Depending on capacity, bathroom scales can also be used.

## TOWING YOUR TRAILER

### WEIGHT DISTRIBUTION HITCHES

The trailer's drawbar should preferably be level when being towed. Towing applies a downward force on the rear of your vehicle which is referred to as 'ball weight'.

This weight will be carried by the rear suspension, which can cause the back of the tow vehicle to sag. In response, the front of the vehicle will rise and the steering will feel light, due to the lower weight on the front wheels. This can cause loss of steering and braking performance (increased wear and tear on the rear suspension and tyres will also result).

Weight distribution hitches will help return your vehicle close to the original dynamics by re-distributing the effects of this ball weight to the original balance between front and rear suspensions, thus levelling out the vehicle/trailer combination.

Remember, Weight Distribution Hitches are not a means of lowering the ball weight, and you still cannot tow more than the maximum ball weight as set out by the vehicle/towbar manufacturer.

You should always consult your vehicle owner's manual for the true towing capacity of your vehicle and match that with the correct towbar.

Fitting of weight distributing hitches is not recommended with over-ride brakes, as the hitch interferes with the application and release of the brakes, and may cause brake malfunction. Neither should they be used in extreme off-road conditions.

**Please Note:** Some vehicle manufacturers require the use of a Weight Distribution Hitch to be able to tow to their stated maximum capacity. You are legally obliged to use them in such situations. A few vehicle manufacturers however prohibit their use.

Also note that some certain types of trailer chassis/drawbars may also prohibit the use of Weight distribution hitches.



WEIGHT DISTRIBUTION HITCH



### SENSIBLE LOADING

How to apportion it.

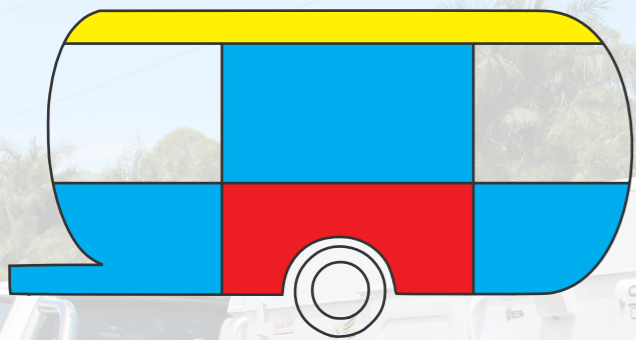

HEAVY ITEMS      MEDIUM ITEMS      LIGHT ITEMS



INCORRECT LOADING



INCORRECT LOADING



### Freedom comes easy in a Jayco...

The simple things in life are always the best, and a feature packed Jayco makes them easier to discover, and easier to enjoy.

So start planning your Jayco adventure today. Visit [jayco.com.au](http://jayco.com.au) or call 1300 52926 78 to find your nearest Jayco dealer.



SILVERLINE CARAVAN



1300 JAYCO RV [JAYCO.COM.AU](http://JAYCO.COM.AU)

## TOWING YOUR TRAILER

### FACTORS IN TRAILER STABILITY AND SWAY

Incorrectly loading your trailer can contribute significantly to stability and sway related issues. Ensuring the load is distributed evenly as per the 'sensible loading' diagram on the previous page is key to minimising any instability. It is also important to consider the effects of loads such as luggage, portable fridges on the towing vehicle.

Incorrect tyre pressures on both the trailer and tow vehicle may in some cases lead to instability on the road.

External Factors such as cross winds and overtaking trucks and buses can also cause significant sway and instability whilst towing.

There are several sway control devices commercially available which may aid in reducing trailer instability:



### AKS 3004 STABILISER

With this device, friction pads apply a high level of pressure on the tow ball. Their high damping force resists sudden movements, either horizontally or vertically to stabilise the caravan when being towed. This stabiliser must only be used with an anti – rotating tow ball.

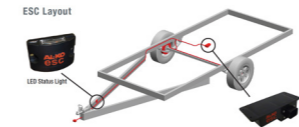

### ELECTRONIC STABILITY CONTROL

This is an electronic stability control system (ESC) which automatically applies the electric brakes, in a controlled manner; to a trailer should sway or a severe manoeuvre occur. This slows down the caravan and stops the sway from increasing.



### FRICITION SWAY CONTROL

This is a device of universal application to all caravan/trailer combinations regardless of tow ball weight or coupling height. It is adjustable to accommodate small to large rigs and normal to severe highway conditions.



### DUAL CAM SWAY CONTROL

This is applicable only to caravan/trailers having heavier tow ball weights. Whereas the Friction Sway Control is adjustable, the Dual Cam has a fixed setting.

**The guidance of an experienced installer is advisable with any of this equipment.**

# INSURANCE

Your recreational vehicle needs to be insured, but choose your policy wisely. You should also bear in mind that your trailer may not be covered by comprehensive insurance if it fails to comply with legislation, or if its ATM exceeds your vehicle's towing capacity, or if it is unroadworthy or overloaded.

## When shopping around for a policy, consider the following:

- Is the policy premium competitive?
- Is the policy an Agreed Value or a Market Value policy?
- Does the policy include the annex and accessories such as air-conditioners?
- Does the policy cover personal contents?
- Is comprehensive flood cover included?

## Emergency Contact Details

Insurance Co: \_\_\_\_\_

Insurance Ph: \_\_\_\_\_

Policy No: \_\_\_\_\_

Rego No: \_\_\_\_\_

Driver Details: \_\_\_\_\_

Emergency Contacts: \_\_\_\_\_



## CIL Insurance is Australia's leading specialist Caravan and RV insurer

### CIL specialist policies include cover for:

- Flood\*, storm, hail and fire at no extra cost
- New vehicle replacement within 2 years of first registration<sup>^</sup>
- Automatic contents cover of up to \$1,000
- Flexible excess options to reduce your premium
- Reasonable costs to collect and deliver your caravan back to you following accident repairs, if the repairer is more than 100kms from your home
- Pay by the month at no extra cost

Call 1800 112 481 for a Quote  
Visit [cilinsurance.com.au](http://cilinsurance.com.au)



Insurance is issued by AAI Limited ABN 48 005 297 807 trading as CIL Insurance. Read the Product Disclosure Statement before you make any decisions regarding our products. Contact us for a copy. \*Flood cover excludes actions or movement of the sea. No cover for loss or damage caused by flood within the first 72 hours from policy commencement. <sup>^</sup>In the event of a total loss and: (a) for Caravan Insurance, the agreed value is not less than the purchase price; and (b) for RV insurance, you are the first registered owner of the vehicle.



## A-FRAME TOWING

A motor vehicle can be flat-towed behind a motorhome using a device commonly known as an A-frame. An A-frame consists of a triangle-shaped frame which provides a means of towing another vehicle without lifting the towed vehicle off the ground.

There are a number of strict legal and safety requirements for A-frame towing which you must implement and include (but are not limited) to:

- Gaining approval to tow with the use of an A-frame
- Attachment mechanism requirements for both the towing and the towed vehicles
- Dimension requirements
- Towing ratio requirements
- Braking, lighting, signage & steering requirements; and
- Manufacturers' requirements.

Vehicle owners must check with the relevant road authority of their State/Territory to determine the requirements of A-frame towing and if it is acceptable.



## REAR MARKING PLATES

A caravan and tow vehicle combination that has an overall length equal to or greater than 7.5m is permitted to carry a "Do not overtake turning vehicle" warning.

This warning entitles the vehicle to 'straddle' or momentarily occupy an adjacent lane when making a turn, with other following vehicles required to give way. The warning can be displayed as a separate sign, or incorporated on the left-hand or both rear marking plates. *Typical signage may look like the signs depicted on the lower right side of this page.*

It is important to note that straddling adjacent lanes whilst turning without the warning sign displayed may be illegal in some jurisdictions, and that some jurisdictions prohibit the use of this signage on vehicle combinations less than 7.5m long.

For more information on the use and fitment of Rear Marking Plates you may wish to refer to Standards Bulletin VSB 12 - Rear Marking Plates - [https://infrastructure.gov.au/roads/vehicle\\_regulation/bulletin/files/VSB\\_12.pdf](https://infrastructure.gov.au/roads/vehicle_regulation/bulletin/files/VSB_12.pdf)

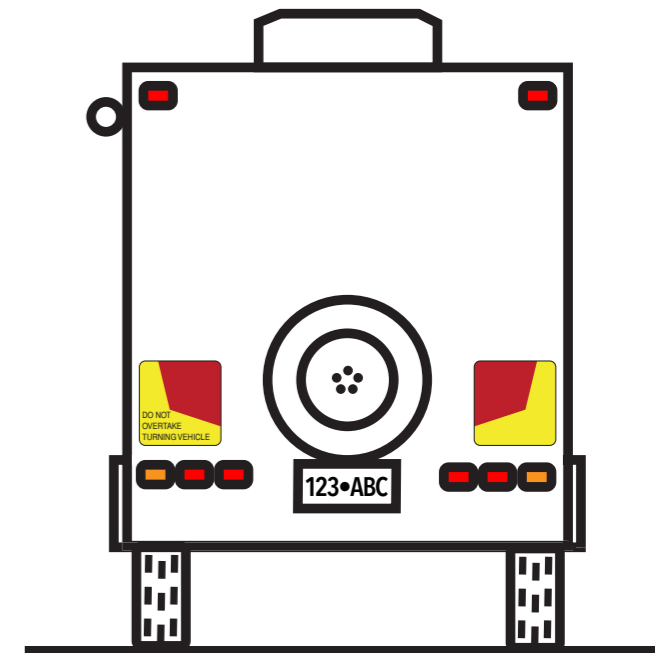

## OFF HIGHWAY TOWING TIPS & TECHNIQUES

- Any trailer or caravan should be driven at speeds with respect to the terrain being traversed, the loads carried and care of both the caravan and towing vehicle.
- Off-highway towing has additional challenges and is only recommended for experienced off-highway drivers.
- Always drive within your capabilities.
- Always drive appropriately for the road/track conditions. Specific vehicle set-up and/or driving techniques may be required for rough roads, corrugations, and steep or narrow tracks.
- Ensure that your caravan design is suitable for use off the highway. If unsure, seek advice from the caravan manufacturer.
- Check your warranty coverage, as some items may not be covered for off-highway driving.
- Be realistic as to where you are going. A large “off-road” caravan is unsuitable for most 4WD/Fire trails as they are too high (overhanging branches etc).
- Use a suitable vehicle; in most cases a Low range capable vehicle is necessary.
- Use an “off-road” style coupling which allows a bigger range of movement on the coupling.
- Have at least basic 4WD skills, knowledge of recovery techniques, picking the best line, using the right gear, understanding the technology in the vehicle etc.
- Have electric brakes fitted to the trailer/caravan. Also know how to set up and use the electric brake controller correctly.
- In an “off-road/highway” situation set the bias on the trailer brakes so that the trailer wheels will lock up before the car, thus preventing the trailer trying to overtake the car.

- Know your approach, ramp over and departure angles and also the angles associated with the drawbar and trailer.
- Know where the vulnerable/low points are underneath both the Car and Trailer.
- Know where the wheels of the car and trailer are travelling. Are the trailer wheels wider apart or narrower than the Tow Vehicle wheels.
- Avoid side slopes as the trailer can easily drag the rear of the car sideways causing roll-over.
- Avoid travelling alone.
- Practice reversing skills as you need the ability to be able to reverse the combination up or down steep inclines and/or around corners on narrow tracks.
- Practice recovery skills and carry the appropriate recovery equipment.
- Ensure that the trailer/caravan has rated recovery points.
- Ensure that the load is located correctly in or on the trailer and is securely fastened.
- Ensure that you do not exceed the Aggregate Trailer Mass as stated on the compliance plate and you also do not exceed the Tow Vehicles rated tow capacity.
- Ensure that you do not exceed the Tow Vehicles Gross Combined Mass. (I.e. the total weight of the car and trailer). This should be in the hand book.
- Some vehicles have a “off Road” tow capacity and/or a speed restriction.
- Carry appropriate spares to suit the trailer and car. For the trailer you should be carrying at least spare bearings, wheel nuts and studs.
- Have a suitable jack that can be used to raise the trailer for changing a flat tyre or repositioning the trailer. You also need to have a suitable wheel brace that fits the nuts on the trailer.

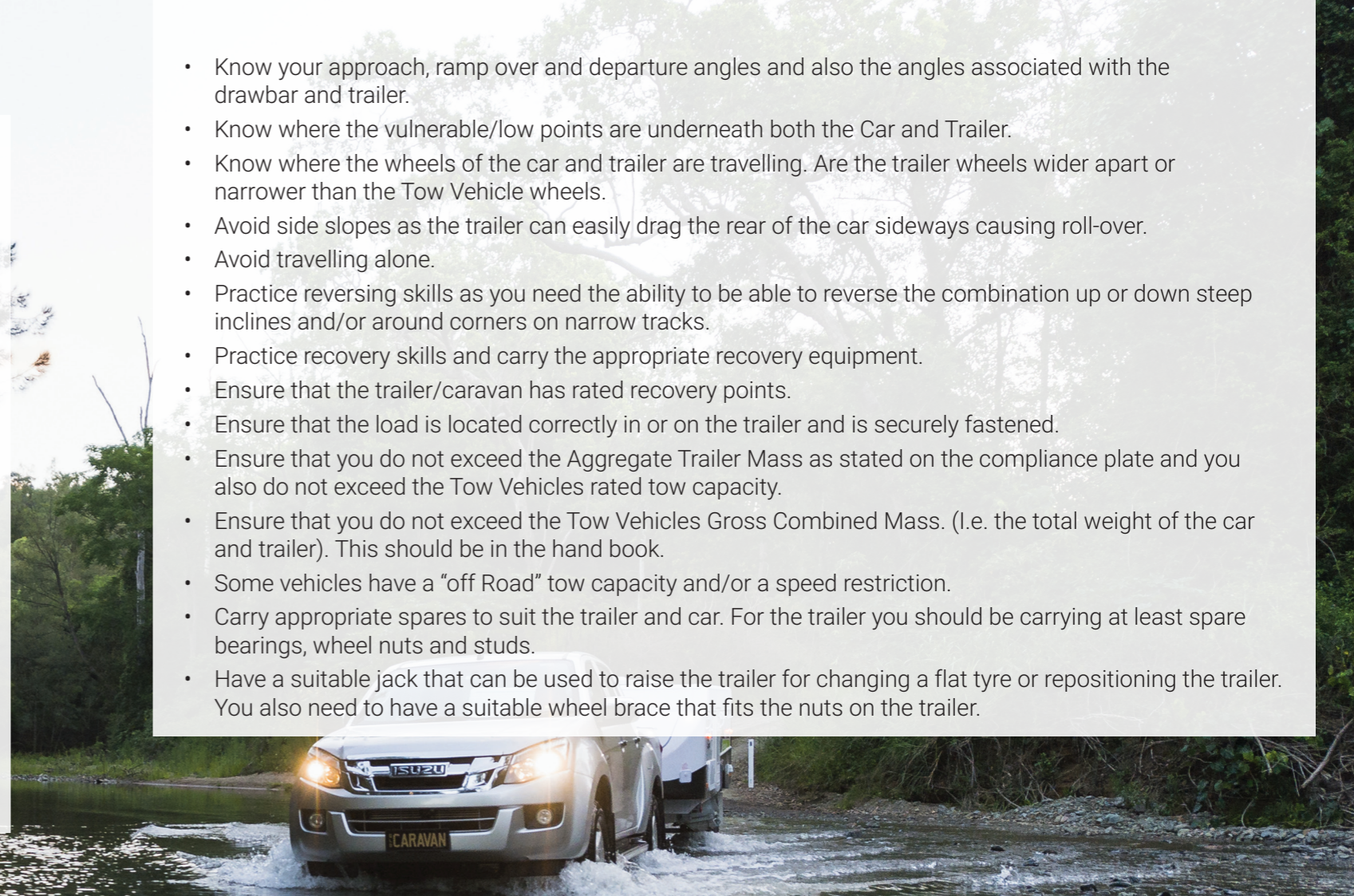



**75% PET FRIENDLY PARKS  
ACROSS AUSTRALIA & NEW ZEALAND**



[www.familyparks.com.au](http://www.familyparks.com.au)

## 5TH WHEELER TOWING

The towing capacity of a vehicle (truck or ute) towing a 5TH wheeler (or gooseneck caravan) is calculated in a different way to that of a normal car or ute. With a 5TH wheeler the tow ball / hitch is located in the tray of the vehicle. Australian Design Rules dictate the type of hitch that must be used, though not the specific location of that hitch.

- If the hitch is behind the rear axle, the front of the towing vehicle lifts under towing conditions.
- If the hitch is over the rear axle, front axle loading stays generally the same.
- If the hitch is in front of the rear axle, front axle loading is increased. A slight front-end lifting effect may occur when speed increases, though this is only noticeable when accelerating hard from a standstill.

5TH WHEELER TOWING MASS GUIDE



With a hitch in this position the tow vehicle can carry much more weight than it could if a caravan was connected to a towball as the fifth wheeler imposes (a great deal more of the mass) some 20% of the mass directly over or slightly in front of the towing vehicle's rear axle.

When calculating the towing capacity of a vehicle for a 5th wheeler the manufacturer's weight ratings of the tow vehicle must not be exceeded by the trailer, specifically the Gross Vehicle Mass (GVM)

and the Gross Combined Mass (GCM). For example if the GCM is 4.5 tonnes and the tow vehicle weighs 2.0 tonnes, then the maximum weight of the fully laden trailer must not exceed 2.5 tonnes.

Whilst it is normal practice to have about 20% of the fifth wheeler's weight carried by the towing vehicle, that weight must not exceed the legal carrying capacity of the tow vehicle, particularly not exceeding the carrying capacity of the tow-vehicles tyres nor the individual axle loading.



## PREPARATION

### MAINTENANCE

Regular maintenance of your vehicle and trailer is essential for safe towing. Have them checked regularly to ensure they are in a safe and roadworthy condition. The trailer's wheel bearings, suspension and brakes must all be in good working order and tyres must be properly inflated. It is a good idea to take some of the mass off your trailer's springs and tyres if it is going to be stationary for an extended period of time.

Gas cylinders and LPG regulators should also be checked regularly by a qualified person. For example, if left out in the open, your regulator may have been affected by water. If this is the case, it needs to be drained and cleaned thoroughly to prevent corrosion, which will prevent it from working properly.

Check that all hoses and pipes are securely connected and also check the date stamp on your cylinders, which must be regularly checked for service life expiry at a certified gas cylinder testing station.

It is illegal to fill cylinders which are beyond their service life.

Please Note: Make sure you do not obscure the number plate or any 12 Volt lighting.

If attaching after-market items or options to the trailer; ensure that the trailer does not become overloaded. The balance and tow-ability of the trailer can be adversely affected. In particular, driving stability may deteriorate and the chassis could be over-stressed by excess weight.

Added options may also change the dimensions of the trailer which may mean that:

- i) It exceeds the overhang allowed past the rear axle
- ii) It exceeds the overall allowable length of the tow vehicle/trailer
- iii) It exceeds the allowable overall width of the trailer

Modifications to your trailer should be carried out by appropriately qualified people, in accordance with Australian Design Rule regulations.



**X** LOAD COVERING NUMBER PLATE

## PREPARATION

### CHECKS BEFORE TRIP

- Check oil, water, brake fluid, the battery etc.
- Inspect all tyres carefully. If your trailer has not been used for a long time, the tyres may be soft. And remember, when towing heavily loaded trailers your vehicle's tyre pressures should be increased to the level recommended in the owner's handbook or on the tyre placard. If in doubt, contact your local tyre dealer.
- Check that your vehicle and trailer's wheel nuts have been tightened to the manufacturer's specifications. To tighten the nuts, use a torque wrench to the torque recommended by the manufacturer.
- Ensure the coupling socket and ball match in size.
- Check that the coup ling is correctly and securely fastened.
- Check that the safety chains are correctly connected.
- Check to ensure that the trailer brake and light connections are secure and that all lights work.
- Check that the towing lights, number plates and registration labels of your caravan are clearly visible.
- Disengage any reversing catch fitted to the trailer coupling (as used with over-ride brakes).

### Make one or two test stops to check that the brakes are working properly.

- Ensure that your load is properly secured. Limit the amount of load in the boot of the tow vehicle.
- Ensure that the rear vision mirrors on the tow vehicle are properly adjusted to ensure a clear view of the road to the rear of the vehicle or vehicle combination.

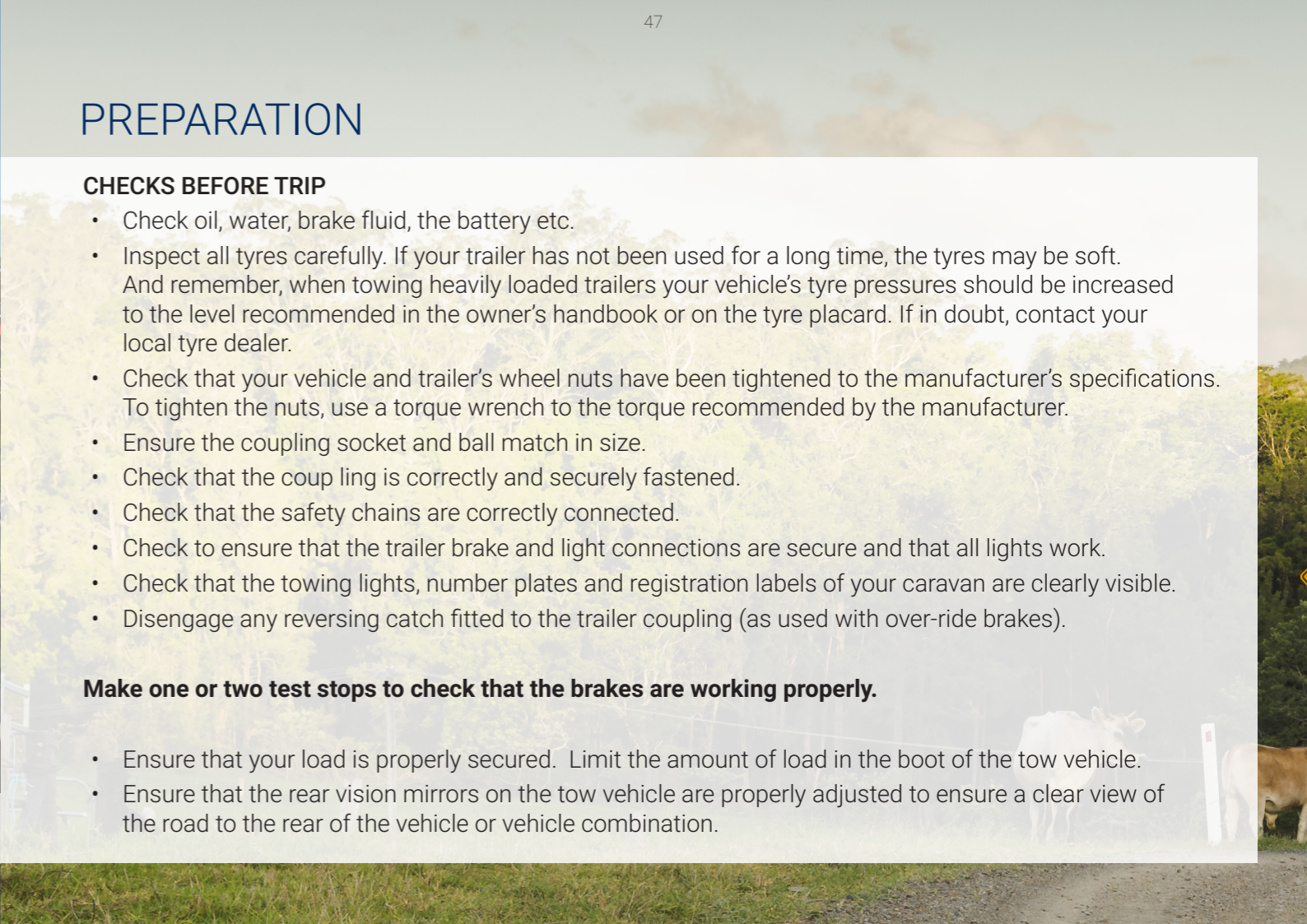



- Ensure that the gas cylinders are properly secured.
- While you are travelling ensure that the gas cylinders are turned off and that the refrigerator door is locked.
- Check that the roll-out awning is stored away and locked in the travel position.
- Remove the jockey wheel from its clamp and store it in the boot of the car or Recreational Vehicle, or if it is of the swivel mount variety, lock it in the travelling position.
- Check that the front and rear corner stabilisers are in the up position.

- Ensure that the hand brake of the trailer has been correctly released.
- Check that the roof hatches, windows, doors and stone shields are secure.
- Check that the electrical cord has been disconnected and stored away.
- Check that the TV antenna is in the travel position.

#### CHECKS DURING THE TRIP:

- Check that the couplings and chains are still securely fastened.
- Check that the brakes and wheel bearings are not overheating, by comparing to your car brakes.
- Check that light connections are still secure and that all lights are working.
- Check that the tyres are still sufficiently inflated.
- Check that the load is still secure.
- Check that the roll-out awning is properly locked in the travel position.



## ORGANISATIONS FOR FURTHER INFORMATION

The Caravan and Camping Industry Associations throughout Australia are pleased to make **The National Caravan & Recreational Vehicle Towing Guide** available to you free of charge.

We hope you find the publication useful and we wish you many hours of happy, safe towing.

#### CARAVAN INDUSTRY ASSOCIATION OF AUSTRALIA LTD

P 03 9815 2015  
F 03 9815 2012  
E [info@caravanindustry.com.au](mailto:info@caravanindustry.com.au)  
W [www.caravanindustry.com.au](http://www.caravanindustry.com.au)

#### CARAVAN AND CAMPING INDUSTRY ASSOCIATION OF NSW

P 02 9615 9999  
F 02 9615 9998  
E [admin@cciansw.com.au](mailto:admin@cciansw.com.au)  
W [www.caravan-camping.com.au](http://www.caravan-camping.com.au)

#### CARAVANNING QUEENSLAND

P 07 3862 1833  
F 07 3262 9890  
E [info@caravanqld.com.au](mailto:info@caravanqld.com.au)  
W [www.caravanqld.com.au](http://www.caravanqld.com.au)

#### CARAVAN TRADE & INDUSTRIES ASSOCIATION OF VICTORIA

P 03 9372 5388  
F 03 9372 5890  
E [info@ciavic.com.au](mailto:info@ciavic.com.au)  
W [www.ciavic.com.au](http://www.ciavic.com.au)

#### CARAVAN AND CAMPING INDUSTRIES ASSOCIATION OF SA

P 08 8272 4468  
F 08 8271 2268  
E [contact@caravanandcampingsa.com.au](mailto:contact@caravanandcampingsa.com.au)  
W [www.caravanandcampingsa.com.au](http://www.caravanandcampingsa.com.au)

Working collaboratively with State Associations on matters which affect the Caravan and Camping Industry



## ORGANISATIONS FOR FURTHER INFORMATION

### CARAVAN INDUSTRY ASSOCIATION WA

P 08 9358 5622  
F 08 9358 5677  
E [info@caravanwa.com.au](mailto:info@caravanwa.com.au)  
W [www.caravanwa.com.au](http://www.caravanwa.com.au)

### CARAVAN PARKS ASSOCIATION OF SA (SA PARKS)

P 08 8363 7255  
F 08 8358 1649  
E [admin@sa-parks.com.au](mailto:admin@sa-parks.com.au)  
W [www.sa-parks.com.au](http://www.sa-parks.com.au)

### CARAVANNING TASMANIA

P 03 6383 4536  
F 03 6383 4925  
E [info@caravanningtasmania.com](mailto:info@caravanningtasmania.com)  
W [www.caravanningtasmania.com.au](http://www.caravanningtasmania.com.au)

### NT CARAVAN PARKS ASSOCIATION

P 08 8952 6111  
F 08 8952 5236  
E [brendan@macrange.com.au](mailto:brendan@macrange.com.au)  
W [www.ntcaravanpark.com.au](http://www.ntcaravanpark.com.au)

### VICTORIAN CARAVAN PARKS ASSOCIATION (VIC PARKS)

P 03 9372 3420  
F 03 9376 9794  
E [admin@vicparks.com.au](mailto:admin@vicparks.com.au)  
W [www.vicparks.com.au](http://www.vicparks.com.au)

### Disclaimer of liability

This publication may not, in part or whole, be copied, reproduced, translated or reduced to any electronic medium without the permission of the publishers. Information provided here is general information only and current at the time of publication. You should check for the most current laws, codes, standards and regulations. We reserve the right to make changes to any aspect of this guide at any time.

While the publishers have taken all reasonable precautions and made all reasonable efforts to ensure the accuracy of material contained in this publication, the publisher accepts no responsibility or liability for any direct or indirect loss or damage, which may result from any inaccuracy or omission, from use of a product or service or reliance upon information contained in this publication. To the fullest extent permitted by law, the publisher disclaims all express or implied warranties including, but not limited to, warranties of satisfactory quality, merchantability and suitability for a particular purpose. You should check with the respective manufacturer(s) to confirm any limitations in relation to your particular vehicle or equipment.

This publication may include advertisements from third party suppliers of products and services. The publisher shall not be liable whether directly or indirectly for the inaccuracy or omission, from use of a product or service, reliance upon information contained in those advertisements or your dealings with third party suppliers. The publisher makes no representations or warranties, express or implied, of any kind with respect to any use of the products and services, including as to quality, suitability, merchantability or fitness of any product or service provided in those advertisements. Any dispute about any products or services provided by the third party suppliers must be resolved directly with the relevant third party suppliers.

© 2018 Caravan Industry Association of Australia, ABN 70 057 668 041



*Education For Those Who Tow*

**Basic & Advanced 4WD**

**Winch Recovery**

**ATV & SSV**

**Trip Preparation**

Nationally Accredited Courses  
Available Throughout  
Australia

**On Road Towing**

**Off Road Towing**

**Chainsaw**

**First Aid**

**1300 660 320 [Getabout.edu.au](http://Getabout.edu.au)**

**Prepare For Your Adventure**





# Australia's most advanced aerodynamic touring caravan.



**Eco Tourer:** The amazing Eco Tourer is a low profile, aerodynamic folding caravan that converts to a spacious solid wall caravan in only seconds. The exciting exterior styling is continued inside with a moulded ceiling and moulded overhead cupboards – similar to that of a luxury motor yacht. Available in **Standard**, **Hybrid** and **Off-Road** versions and with a choice of

three internal layouts: **Double bed**, **Two Single beds**, or **Double Bed with Shower and Toilet**. The Eco Tourer is an easy to tow luxury caravan that can be stored in a standard garage thanks to its low profile roof line and fold-up A-frame. Please call for more information, or visit the web site.

[www.ecotourer.com.au](http://www.ecotourer.com.au)

**VIC: Caravan Court**

639 Springvale Road, Springvale South 3172

**Ph: 03 9546 9822**

**QLD: Caravan Court**

Jackman Street, Southport 4215

**Ph: 0419 736 666 David**

(By appointment only)